

TP SERIES

Tractor spreader featuring both
delivery roller and spreading disc



– de-icing of roads!

TP SERIES

Multi-function spreader – 3 concepts in one spreader

Epoke A/S is now offering the new TP-tractor spreader for winter road maintenance. With a focus on usability and flexibility the tractor spreader combines the following 3 concepts: delivery by roller, delivery by disc, and delivery with prewetting.

A TP-spreader is an investment preparing the customer well for road service during the changeable winter weather.

The driver may easily switch between the different spreading concepts without the use of tools.

The spreader is available in 2 versions featuring basic hoppers of 300 liters and 900 liters, respectively. If desired, an extension hopper may be added for increased capacity.

Spreading by delivery roller

The TP-spreader featuring a delivery roller enables small and large deliveries of both salt and sand in sharply defined widths equaling the machine widths. The roller dosing principle ensures an even material supply to the road surface, and if the spreading material is wet or sticky the auger prevents material "bridge-building" inside the hopper and thus possible stop of spreading.

Spreading by disc

Winter road maintenance is carried out in varying environments, which requires material spreading in varying widths. Therefore, the TP-series features a spreading disc, which allows the spreading of salt or gravel in widths ranging from 1-6 meters. Depending on the environment it's possible to adjust the spreading disc to spread symmetrically or asymmetrically.

Prewetting (option)

If spreading with prewetted salt is desired, the tractor spreader may be equipped with a prewetting system and thus used to provide service on slippery roads and paths where prewetted salt is a requirement.



The TP-series features both delivery roller and spreading disc

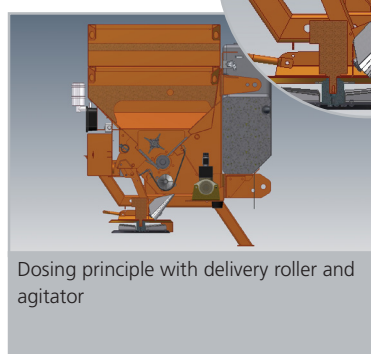

Dosing principle with delivery roller and agitator

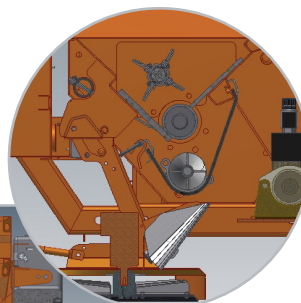

User-friendly folding cover

Remote controller

As standard the TP-spreaders feature the EpoSet remote controller. The EpoBasic remote controller, which is optionally available, offers road-speed relation and spreading symmetry adjustment.

Service

All vital components, such as hydraulic and electronic parts have been placed in the machine house on the rear of the spreader. Here the parts are well protected and easily accessible when servicing the machine.

Technical data	TP3	TP9
Hopper capacity	300 l	900 l
Extension frame	100 & 200 l	300 & 600 l
Total width	1300 mm	2100 mm
Spreading width, disc	1.5 til 6 m	1.5 til 6 m
Spreading width, delivery roller	1.2 m	1.8 m
Weight	315 kg	435 kg
Mounting on tractor	From 1 t	From 3 t
Drive	Hydraulics	Hydraulics
3-point suspension	Category 1 + 2	Category 2 + 3



Epoke® A/S
 Vejenvvej 50, Askov
 DK-6600 Vejen
 Tel. +45 76 96 22 00
 Fax +45 75 36 38 67
 epoke@epoke.dk
 www.epoke.dk



In order to maintain the high and uniform product standard Epoke® A/S has been certified by Lloyd's register to ISO 9001:2008.
 TLG B-3 approval
 GS approval
 E1 approval
 RoHS directive
 WEEE directive

